



A6 RUNNING BOARDS

Assembly, Installation, Operation,
and Maintenance Instructions

PART NUMBER	AL6003B
INSTALL TIME	120 MINUTES

2014-2018 CHEVROLET SILVERADO / GMC SIERRA 1500 DOUBLE CAB
2014-2019 CHEVROLET SILVERADO / GMC SIERRA 2500/3500 DOUBLE CAB (INCLUDES DIESEL W/DEF TANKS)

DEALER / INSTALLER	Provide a copy of these instructions to the end user of this product. These instructions provide important operating and safety information for proper usage of this product. Demonstrate the proper use of the product with the end user. Have the end user demonstrate that they understand the proper use of the product.
END USER	Read and follow all instructions included in this manual. Ask your Dealer/Installer for assistance if you do not understand the proper use of the product. Never remove any decals from the product. Failure to follow these instructions can result in injury or death.

PACKAGE CONTENTS

RUNNING BOARDS (76in)	2	8-1.25mm CLIP-ON NUTS	11
DRIVER/LEFT MOUNTING BRACKETS	3	8-1.25mm X 25mm HEX BOLTS	13
PASSENGER/RIGHT MOUNTING BRACKETS	2	8mm X 24mm X 2mm STD FLAT WASHERS	25
PASSENGER/RIGHT FRONT UPPER BRACKET	1	8mm LOCK WASHERS	25
PASSENGER/RIGHT FRONT LOWER BRACKET	1	8mm NYLON LOCK NUT	1
8mm T-BOLTS	12	8mm HEX NUTS	12
8mm SINGLE BOLT PLATE	1		

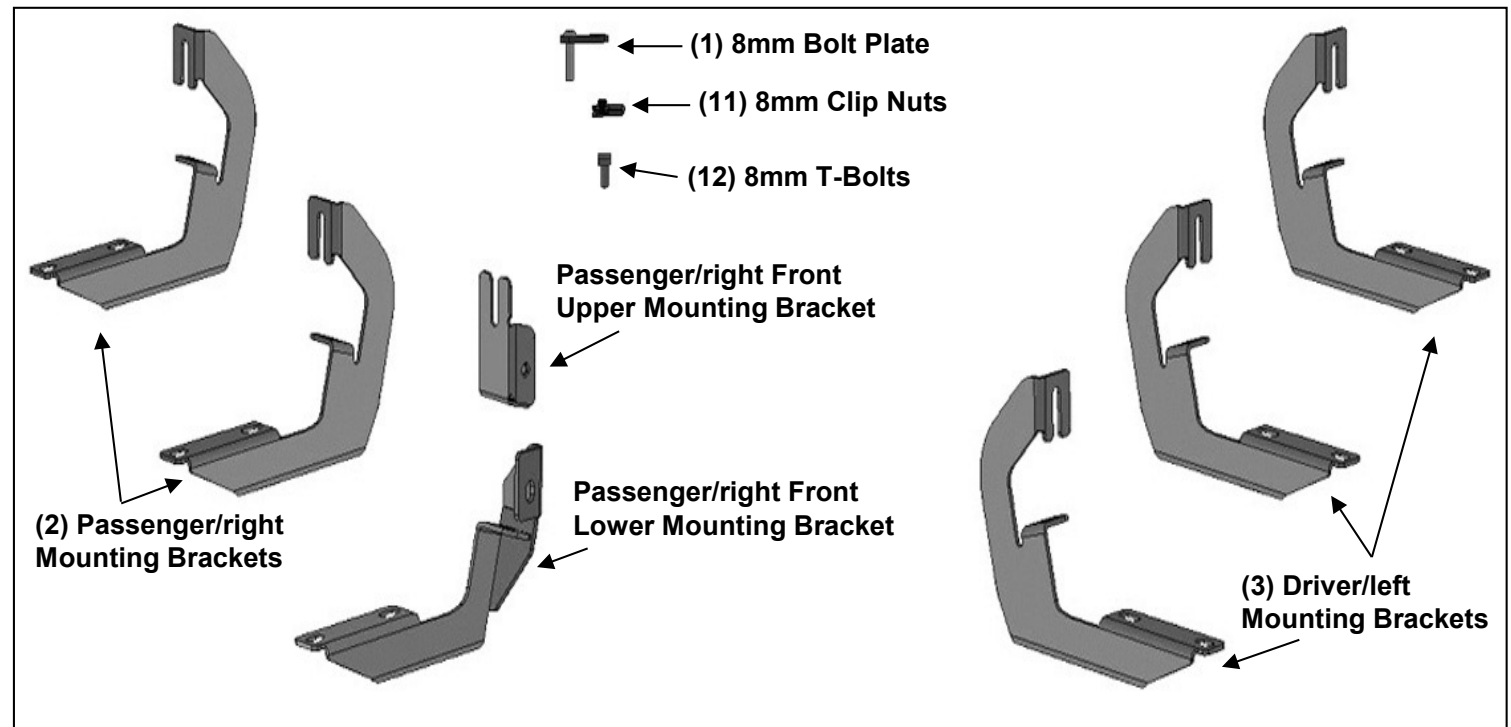

PROCEDURE

REMOVE CONTENTS FROM BOX. VERIFY ALL PARTS ARE PRESENT. READ INSTRUCTIONS CAREFULLY BEFORE STARTING INSTALLATION. ASSISTANCE IS RECOMMENDED. ON MODELS WITH DEF TANK, SELECT A FLAT, LEVEL AREA FOR INSTALLATION. MAY REQUIRE CUTTING.

1. Start the installation under the driver/left side of the vehicle, **(Figure 1)**. Locate the 4 tabs along the bottom edge of the body, (pinch weld). Mounting Brackets will attach to the 1st, 2nd, (just in front of center of cab), and 4th mounting tabs. Directly above each tab is a top mounting location on the side of the body panel, **(Figures 2-5)**. Hold a Bracket up in place to help determine the mounting holes to use along the body.
2. Determine the correct procedure for your model/year and each Bracket location:

Bottom mounting location on the edge of the pinch weld.

- a. Flat tab on pinch weld with factory installed weld nut:
- b. Thread hex bolt into weld nut from the backside-down to clear paint from threads, **(Figure 2)**.

Flat tab on pinch weld with hole:

- a. Select (1) 8mm Clip Nut. Slide the Clip Nut over the tab with the nut facing up behind the tab, **(Figures 3-5)**. Line up threaded nut with hole in the tab. Repeat for each mounting location.
- b. Locate top mounting location on the back side of the body panel.

Models with factory installed threaded insert in body panel:

- a. Thread 8mm Hex Bolt into threaded insert to clear paint as required, **(Figures 2 & 3)**.

Driver/Left Side Installation Pictured

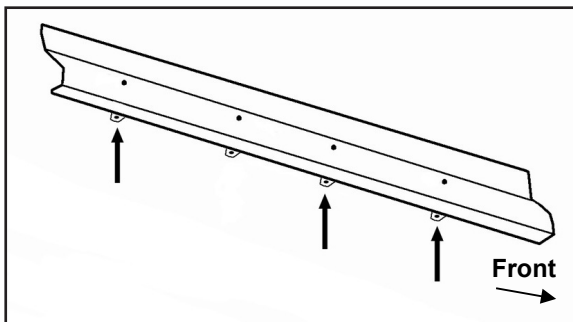

(Figure 1) Driver/left side (3) mounting locations.

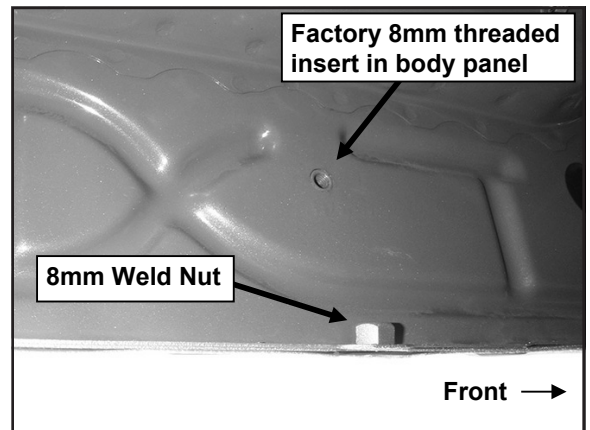

(Figure 2) Passenger/right side front mounting location with weld nut pictured for example.

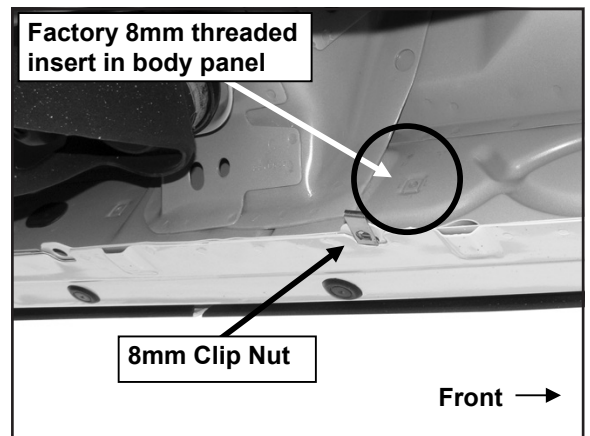

(Figure 3) Driver/left side center location with tab and 8mm Clip Nut.

PROCEDURE (CONTINUED)

b. Large and small hole in side of body panel:

c. Remove the rubber plug from the larger hole, **(Figure 4)**. Select (1) 8mm Clip Nut. Slide the Clip Nut into the larger hole. Line up the threaded nut with the smaller hole, **(Figure 5)**.

3. Select (1) driver/left Mounting Bracket. Attach the Mounting Bracket to the Clip Nuts and/or the factory threaded holes with (2) 8mm x 25mm Hex Bolts, (2) 8mm Lock Washers and (2) 8mm Flat Washers, **(Figures 6-8)**. Snug but do not fully tighten the hardware.

4. Repeat **Steps 1-3** to install the driver/left center and rear Mounting Brackets.

Driver/Left Side Installation Pictured

(2) 8mm x 25mm Hex Bolts
(2) 8mm Lock Washers
(2) 8mm Flat Washers

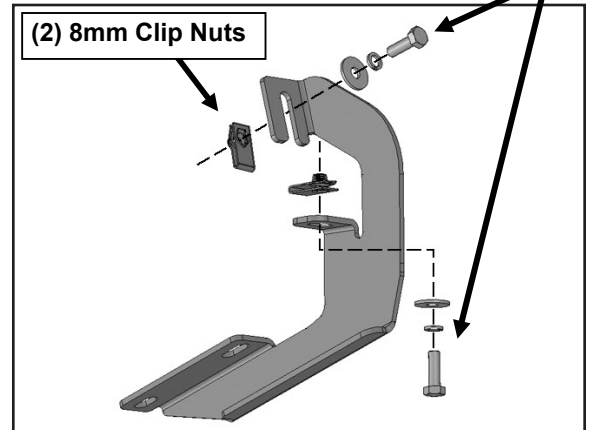

(Figure 6) Attach driver/left Mounting Brackets.

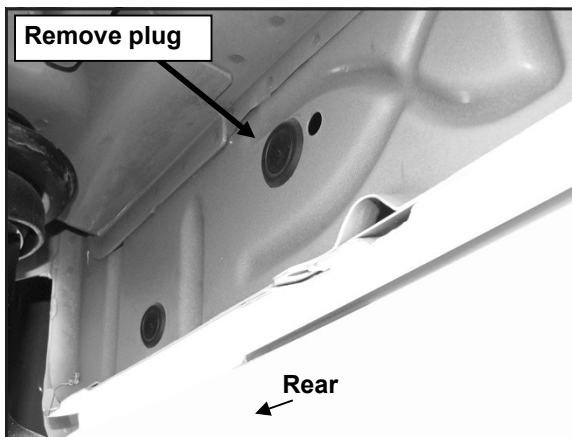

(Figure 4) Driver/left side rear mounting location.

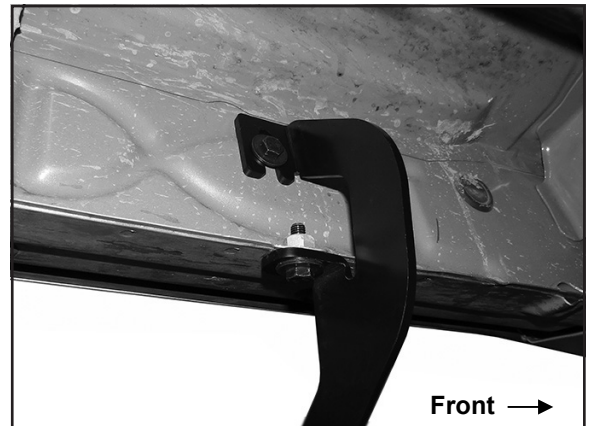

(Figure 7) Example of driver/left front Bracket attached to location with factory threaded mounting holes.

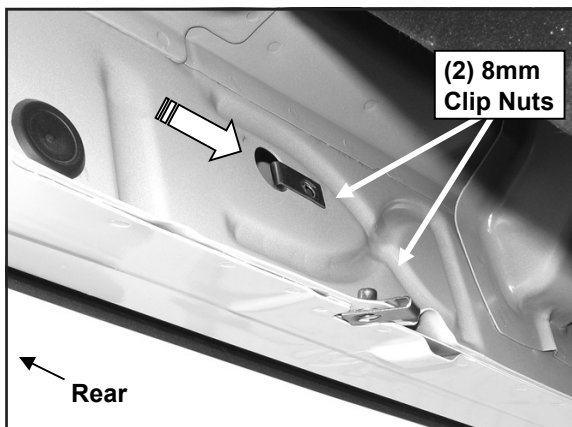

(Figure 5) Driver/left rear mounting location with 8mm Clip Nuts.



(Figure 8) Example of driver/left rear Bracket attached to location with 8mm Clip Nuts.

PROCEDURE (CONTINUED)

5. Carefully unwrap the Running Boards. Select (1) Running Board. Insert (3) T-Bolts into each channel in the bottom of the Running Board, **(Figure 9)**.
6. With assistance, place the Running Board on top of the Brackets. Guide the T-Bolts in the Running Board down through the slots in the Brackets, **(Figures 10 & 11)**. **IMPORTANT:** Do not slide, (front to back), the Running Board on the Brackets or damage to the finish may result.
7. Attach the Running Board to the Brackets with (6) 8mm Flat Washers, (6) 8mm Lock Washers and (6) 8mm Hex Nuts, **(Figures 10 & 11)**. Do not tighten hardware.
8. Level and adjust the Running Board to the vehicle and tighten all hardware.

Driver/Left Side Installation Pictured

(2) 8mm Flat Washers
(2) 8mm Lock Washers
(2) 8mm Hex Nuts

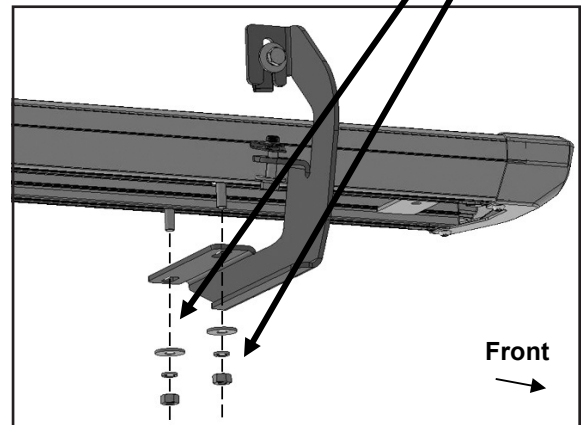

(Figure 10) Attach Running Board to driver/left front Mounting Bracket.

(2) 8mm Flat Washers
(2) 8mm Lock Washers
(2) 8mm Hex Nuts

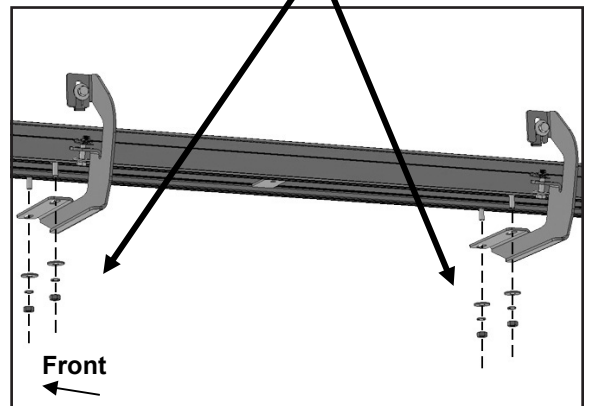

(Figure 11) Attach Running Board to driver/left center and rear Mounting Brackets.

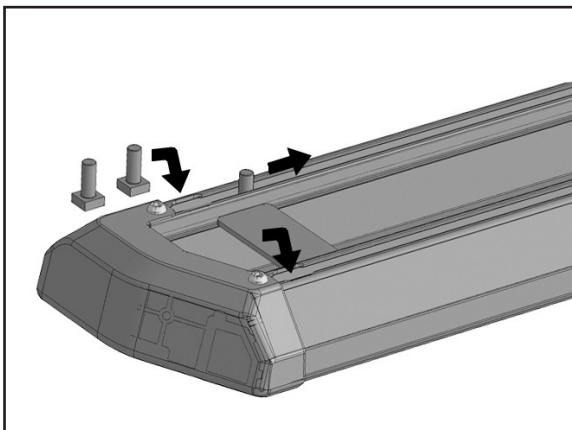

(Figure 9) Slide (3) 8mm T-Bolts into each channel in bottom of Running Board.

PROCEDURE (CONTINUED)

9. Move to the passenger/right side of the vehicle. On the passenger/right side, determine if the vehicle is equipped with a plastic diesel exhaust fluid (DEF) tank, (Figures 12 & 14A).

Models without DEF tank, skip to Step 10.

2014-16 Models with DEF tank:

The tank sits close to the side of the body. With specialized tools, the passenger/right front upper and lower Bracket can be installed but room is limited. It may be easier to drop the tank down to access the inner side of the body panel for upper bracket installation. Tank will not need to be removed, only dropped down for access to mounting location. **IMPORTANT:** If tank is full, it will be very heavy, and assistance is highly recommended to avoid injury or damage to the vehicle or the tank. It is recommended that installation is performed when the DEF tank is low on fluid before dropping the tank.

a. On 2014-16 models with plastic lower tray under tank, remove the (3) hex bolts attaching the tray to the frame, (Figure 12), and remove tray.

b. Release the tank filler hose. Release the plug for the sending unit on the top of the tank.

c. Support the tank with a floor jack. Place a smooth flat surface, (wooden block for example), between the floor jack and the tank to avoid damaging the plastic tank. Do not push up on the tank; only support the weight of the tank with the jack.

d. Remove the (2) bolts securing the tank straps to the vehicle, (Figure 13). Tilt the straps to release straps from the brackets. Slowly lower the tank until the top of the tank is almost visible. Use blocks or stands to support the tank while installing the front Upper and Lower Brackets.

e. Proceed to **Step 10.**

Passenger/Right Side Installation Pictured

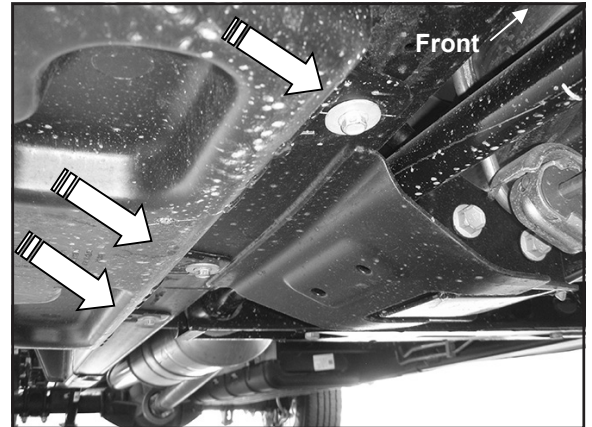

(Figure 12) 14-16 Passenger side front pictured with DEF tank cover. Remove (3) hex bolts to remove cover.

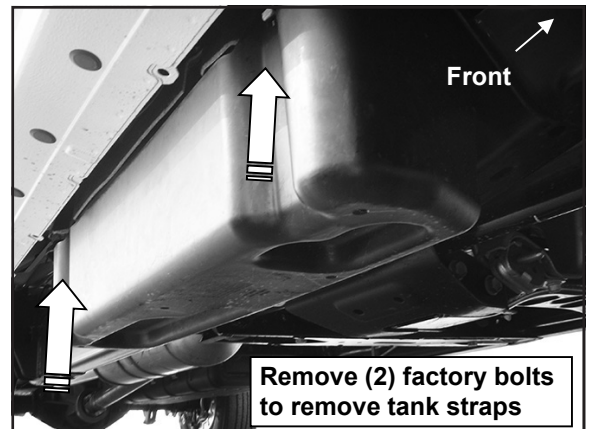

(Figure 13) 14-16 Passenger side DEF tank and cover.

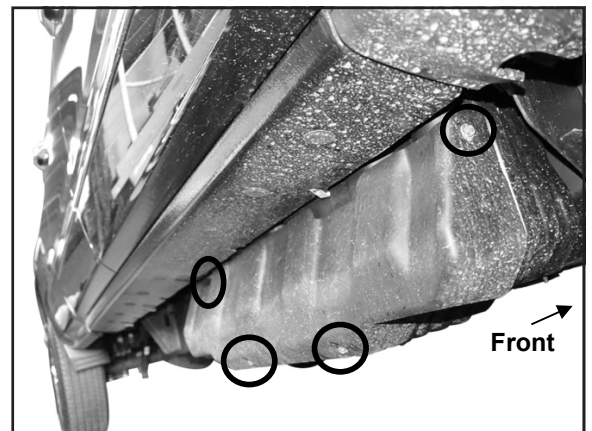

(Figure 14A) 2017-on Passenger/right side pictured with DEF plastic tank cover. Remove (4) hex bolts to remove plastic cover.

PROCEDURE (CONTINUED)

2017-on Models with DEF tank:

Remove only the plastic cover from the tank, **do not remove tank**, (Figures 14A & 14B).

10. Locate the first tab on the edge of the pinch weld, (Figures 2, 16 & 19). Select the passenger/right Upper Bracket, (Figure 15). Repeat Steps 2 & 3 to attach the Upper Bracket to the side of the body panel, (Figure 16). Do not tighten hardware at this time.

11. Line up the hole in the bottom of the Upper Bracket with the hole in the tab on the pinch weld.

Models with a weld-nut:

a. Slide the bottom of the Bracket over the weld-nut, (Figure 16).

b. Select the passenger/right Front Lower Bracket. Attach the Lower Bracket to the bottom of the body, weld-nut and Upper Bracket with (1) 8mm x 25mm Hex Bolt, (1) 8mm Lock Washer and (1) 8mm Flat Washer, (Figure 17). Leave loose at this time.

Passenger/Right Side Installation Pictured

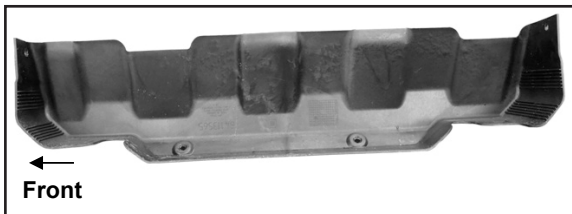

(Figure 14B) 2017 Passenger side DEF cover removed.

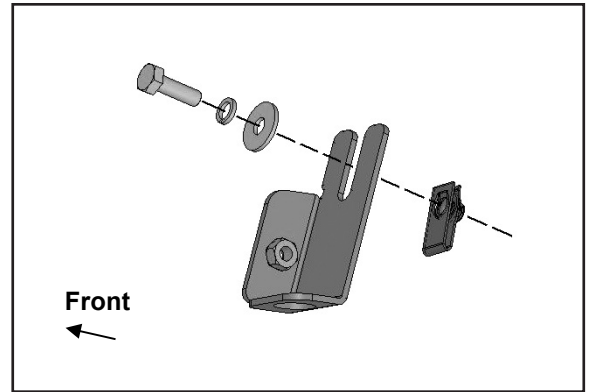

(Figure 15) Passenger/right Front Upper Bracket.

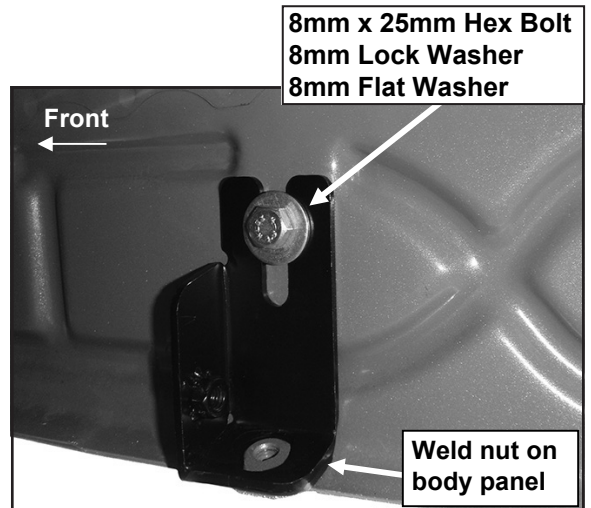

(Figure 16) Slide Upper Bracket over weld nut if equipped-also see (Figure 2).

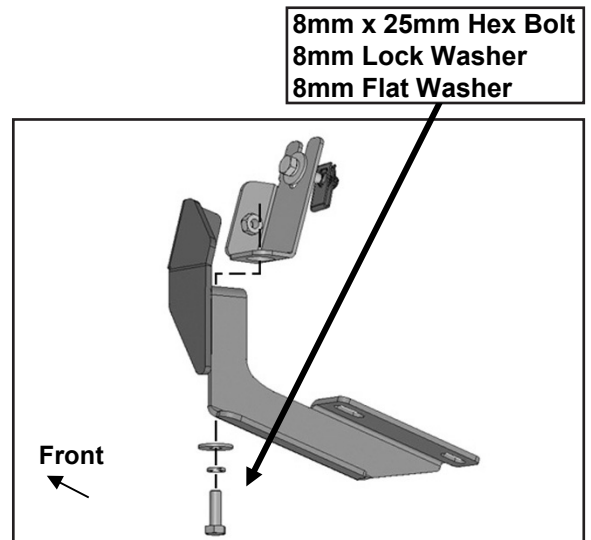

(Figure 17) On models with weld nut on pinch weld, attach passenger/right Front Lower Bracket to Upper Bracket and bottom of body.

PROCEDURE (CONTINUED)

Models with flat tab and hole:

a. Insert the 8mm Bolt Plate down through the hole in the Upper Bracket and mounting tab, **(Figures 18 & 19)**.

b. Attach the Lower Bracket to the bottom of the body and Bolt Plate with (1) 8mm Flat Washer and (1) 8mm Nylon Lock Nut, **(Figure 20)**. Do not tighten hardware.

12. Line up the side tab on the Lower Bracket with the threaded hole in the side of the Upper Bracket. Attach the Lower Bracket to the Upper Bracket with (1) 8mm x 25mm Hex Bolt, (1) 8mm Lock Washer and (1) 8mm Flat Washer, **(Figure 21)**. Leave loose at this time.

Passenger/Right Side Installation Pictured

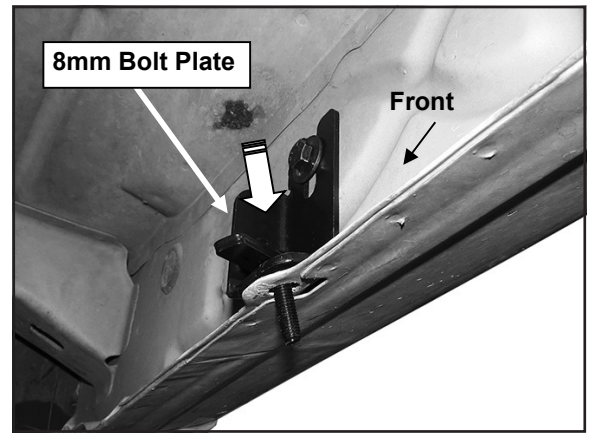

(Figure 19) On models with flat tab (see Figure 3 & 4), insert 8mm Bolt Plate (Figure 17) down through Upper Bracket and mounting tab.

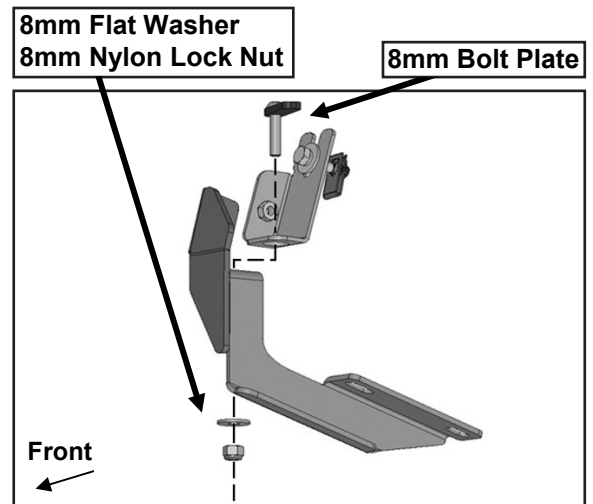

(Figure 20) On models with flat tab, attach passenger/right Front Lower Bracket to Upper Bracket and bottom of body.



(Figure 18) 8mm x 35mm Bolt Plate.

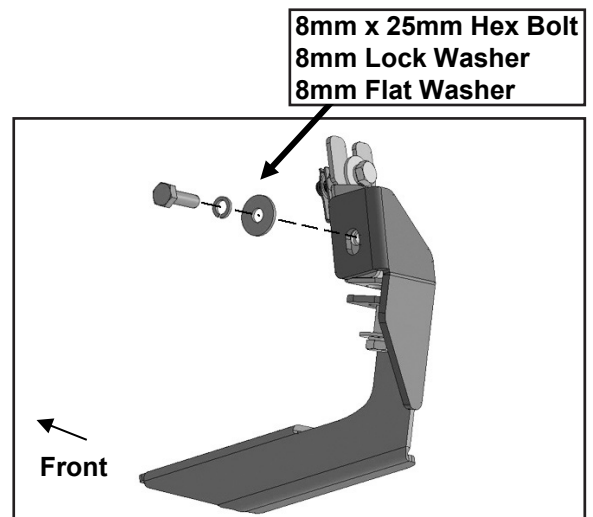

(Figure 21) Attach Front Lower Bracket to front facing side of Upper Bracket.

PROCEDURE (CONTINUED)

13. Move along the bottom of the body to the center mounting location. Repeat **Steps 1-3** to install (1) passenger/right Mounting Bracket, **(Figure 22)**. Repeat this Step to attach the rear mounting Bracket, **(Figure 22)**.

14. Repeat **Steps 5-8** to attach the passenger/right side Running Board, **(Figure 22)**. Measure the distance from driver/left front wheel opening or mud flap to front end of Running Board. Match the passenger/right Running Board to the driver/left side installation.

15. Once the Running Boards are installed, lined up to side of vehicle and all hardware fully tightened, reinstall the DEF tank and cover, if equipped, as described in **Step 9**.

a. 2017-on 2500-3500 DEF tank models only: Hold the DEF cover up in place and mark the 2nd Bracket location onto the cover, **(Figure 23)**. Use a sharp knife or hacksaw blade to carefully cut a slot in the plastic cover to clear the 2nd Bracket, **(Figure 24)**, and reinstall.

16. Do periodic inspections to the installation to make sure that all hardware is secure and tight.

Passenger/Right Side Installation Pictured

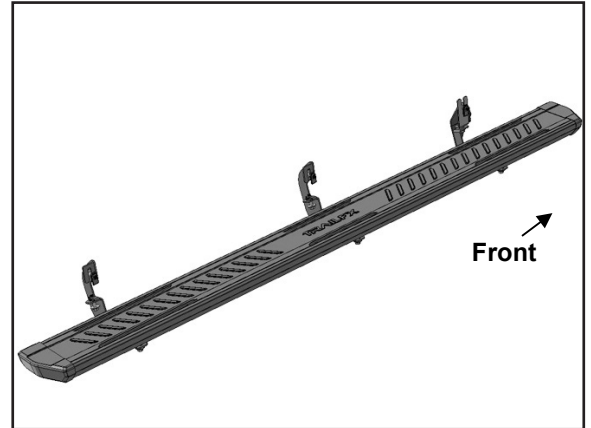

(Figure 22) Complete passenger/right side assembly illustrated.

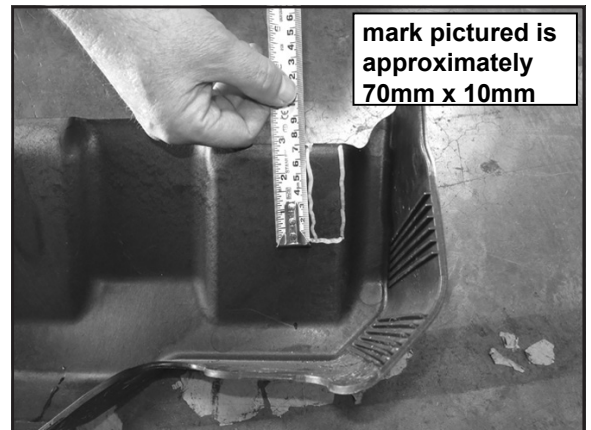

(Figure 23) 2017 Passenger side DEF cover marked for trimming.

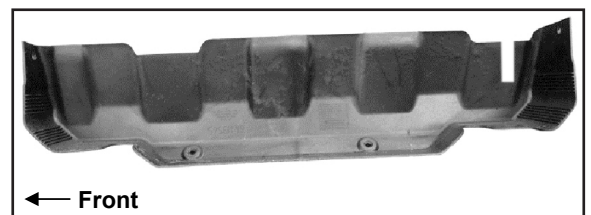

(Figure 24) 2017-on Passenger side DEF cut for example only.

PRODUCT CARE

- Periodically check the product to ensure all fasteners are tight and components are intact.
- Regular waxing is recommended to protect the finish of the product.
- Use ONLY Non-Abrasive automotive wax. Use of any soap, polish or wax that contains an abrasive is detrimental and can scratch the finish leading to corrosion.
- Mild soap may be used to clean the product for Black finish.

FAQs

Hardware and mounting brackets are not aligning properly.	Ensure that hardware is being used on the correct side of vehicle. In some cases, the hardware may appear the same for driver and passenger side but may alter the alignment of mounting location. Check mounting brackets for both sides.
Products are thumping / rattling after Installation.	Ensure that all required mounting brackets/hardware's are installed & tightened correctly. Suggest using white Lithium/regular grease between metal-to-metal contact.
Missing / Excess Hardware.	Recheck hardware count as per the part list.
Product not installing properly.	Ensure the Year/Make/Model as well as cab and bed dimensions are correct for the application. Review all steps for installation to ensure they were followed correctly.
Who should be contacted for questions regarding product / installation assistance?	www.trailfx.com / support@trailfx.com or 1-(866) 638-4870

CONTACT US

WEBSITE: TrailFX.com

PHONE: 1-866-638-4870

EMAIL: support@trailfx.com

WARRANTY TERMS

Black Powder Coated: Limited Lifetime Warranty

TrailFX and Keystone Automotive Operations Inc. make no guarantees or warranties for products not manufactured by Keystone Automotive Operations Inc. Such products are covered solely under any applicable warranty of the manufacturer. It is always recommended that the operating instructions and warranty instructions provided by the manufacturer are followed.

Keystone Automotive Operations Inc. warrants its products to be free from manufacturing and material defects to the original purchaser for the length of warranty stated above from the date of retail purchase. If any products are found to have a manufacturing or material defect, the product will be replaced or repaired at the option of TrailFX and Keystone Automotive Operations Inc. with proof of purchase by the original purchaser. The original purchaser shall pay all transportation and shipping costs associated with the return of the defective product and the defective product shall become the property of Keystone Automotive Operations Inc.

This Warranty applies to Keystone Automotive Operations Inc. products used for individual and recreational purposes. Commercial usage of the Keystone Automotive Operations Inc. products limits the warranty to 90 days from the date of purchase.

This Warranty applies only to Keystone Automotive Operations Inc. products which are found to be defective in manufacturing or material. This warranty does not apply to normal wear and tear of the finish placed on Keystone Automotive Operations Inc. products.

TrailFX and Keystone Automotive Operations Inc. are not responsible for any labor costs incurred for removal or replacement of the defective product.

TrailFX and Keystone Automotive Operations Inc. are not responsible for repair or replacement of any product under the limited warranty where the product was improperly installed, misapplied, altered, abused, neglected, overloaded, misused, or damaged as a result of an accident, including any use of the product not in accordance with all products operating and safety instructions.

Without limiting the generality of the foregoing, TrailFX and Keystone Automotive Operations Inc. shall under no circumstances be liable for any incidental or consequential loss or damage whatsoever arising out of, or in any way relating to any such breach of warranty or claimed defect in, or non-performance of the products. Some states do not allow the exclusion or limitation of incidental or consequential damages, so the above exclusion or limitation may not apply to you.

This limited warranty gives you specific legal rights, and you may also have other rights that vary from state to state.